



TRAILER ESTATES Park & Recreation District

1903 69TH AVENUE WEST, BRADENTON, FL • 941-756-7177

July 2025

TRIBUNE

Published monthly by On Trac Publishing
P.O. Box 161, Ellenton, FL 34222 (941) 723-5003

Notes from the Park Manager

Dear TE Property Owners,
Happy July!

As we step into the heart of summer, here are a few important updates, reminders, and friendly tips to help keep our community running smoothly and safely.

Hurricane Season Reminder

We are now in the middle of hurricane season. Please review your emergency plans and stock up on essentials.

If you need assistance with hurricane preparedness, check out our website www.trailerestates.com or reach out to the office—we have helpful resources and contact information for local resources through the County and State.

Summer Maintenance

Our Maintenance team will be conducting routine park maintenance throughout the month, including:

- Tree trimming
- Moving back into our newly repaired Maintenance building
- Painting Touch-ups throughout the common areas
- Termite Tenting of the Office & Hall complex July 24-28*

We appreciate your cooperation and patience during this time.

4th of July Safety

Please do not set off Fireworks within the park for safety reasons. However, we encourage you to enjoy local fireworks displays safely and responsibly.

Lawn & Lot Maintenance

All residents are reminded to maintain their lawns (it's the rainy season after all!) and keep lots free of junk & clutter.

Please check skirting and tie-downs.

Office Hours & Contact

Office will be closed on Thursday, July 4th for Independence Day. Office will be closed on Thursday July 24, 2025 through July 28, 2025 for Termite Tenting.

Staff will still answer phone calls and be able to do FOB renewals when the offices are tented.

Please call the regular number 941-756-7177 x101.

Deed Restrictions Update

The TE Board of Trustees are asking for your input when they start discussing changes to update our Deed Restrictions. Please make your suggestions known by sending us an email – manager@trailerestates.com.

Thank you for being a valued part of our community!
Stay Safe and Well-

Lee



DISTRICT CLOSURES IN JULY

On July 4th the TE Office will be CLOSED.

On July 24th & 25th the TE Office will be CLOSED, but phones will be manned during normal business hours.

On July 24th, 25th & 26th, the Large Hall, Mark's Hall and the breezeway bathrooms will be CLOSED while the District tents for termites.



TRAILER ESTATES SUMMER OFFICE HOURS

MONDAY, TUESDAY, WEDNESDAY & FRIDAY

9AM to 12PM & 1PM to 3PM

THURSDAY: 9AM to 12PM & 1PM to 4PM

Unless Otherwise Posted

CLOSED HOLIDAYS: New Year's Day, Memorial Day, Independence Day, Labor Day, Thanksgiving Day and the day after, and Christmas Day.

Any other closures will be announced as needed via Channel 732 and/or posted on the office window.

TE WEBSITE	www.trailerestates.com
EMAIL ADDRESS	trailerestates@trailerestates.com



3801 Bee Ridge Rd. Suite 2, Sarasota, FL 34233
 patsellssrq@aol.com

PAT (REID) BACHERT (941) 586-9766
 licensed real estate professional

SELLING YOUR TRAILER ESTATES HOME???

**GETTING YOU A...FASTER SALE
 AT A...HIGHER PRICE**

with
 Multiple Websites, Flyers
 Newspaper Ads & *Hard Work!*
Call Me

**SPECIALIZING IN 55+
 MOBILE HOME COMMUNITIES**

**ABSENTEE OWNER? FAMILY ESTATE?
 Beginning to End...**
 I complete the job while you stay home.

CALL PAT (941) 586-9766

Your
**MANUFACTURED & MOBILE HOME
 Insurance Specialist**

**Manufactured • Mobile
 Park Model • Cars
 Boats • Golf Carts**

Great Options...Great Prices



**BASSINE
 INSURANCE
 AGENCY, LLC**

909 Pondella Road., N. Ft. Myers, FL 33903
 at the corner of Pondella Rd. & Orange Grove Blvd.

Phone 239-995-0333

E-mail: mh@bassineinsurance.com

**Tropic-Air
 Conditioning inc.**



www.TropicAirFL.com

LIC# CAC1814122

**24/7
 Service
 Available**



Installation, Maintenance & Repair Priced Right!

FINANCING AVAILABLE

**FREE Service Call
 With Paid Repair**

Must present ad. Offers cannot be
 combined. Restrictions may apply.
 Expires 7/31/25

*Best
 Deal*

\$49⁹⁵

**Maintenance
 Special* (reg. \$79)**

Must present ad. Offers cannot be
 combined. Restrictions may apply.
 Expires 7/31/25

HVAC Installation, Maintenance & Repair | Duct Cleaning | Attic Insulation

**We honor all
 manufacturers
 warranties**

CALL TODAY FOR YOUR FREE ESTIMATE!

941-751-2653

**ASK ABOUT
 UV LIGHT!**

TRAILER ESTATES PARK and RECREATION DISTRICT TRAILER ESTATES BOARD OF TRUSTEES 2025

Name	Office Phone & Ext.	Title	Email
Duane Trotter	941-756-7177 x105	Chairman	Dtrotter@trailerestates.com
Richard Fernandez	941-756-7177 x111	Public Relations North	Rfernandez@trailerestates.com
Lori Dalton	941-756-7177 x104	Secretary	Ldalton@trailerestates.com
VACANT	941-756-7177 x109	Treasurer	
Todd Lombardi	941-756-7177 x108	Maintenance	Tlombardi@trailerestates.com
Rodney Smith	941-756-7177 x110	Public Relations South	Rsmith@trailerestates.com
Margo Fegley	941-756-7177 x106	Seasonal Recreation	Mfegley@trailerestates.com
Kathleen Gregory	941-756-7177 x107	Continuing Recreation	Kgregory@trailerestates.com
Lenora Neal	941-756-7177 x103	Health & Welfare	Lneal@trailerestates.com

Important Phone Numbers

EMERGENCY	911	
NON EMERGENCY (SHERIFF'S OFFICE)		941-747-3011
FLORIDA MARINE PATROL		800-342-5367
T.E. MARINA		941-758-4471
TREASURE BARN CALL BARB		941-405-9866
PARK OFFICE		941-756-7177
T.E. FAX		941-755-2937
CHURCH OFFICE		941-756-7722
FLORIDA POWER & LIGHT		941-917-0708
MCUD (WATER)		941-792-8811
WASTE PRO		941-355-9600
SPECTRUM		855-222-0102
ANIMAL CONTROL		941-742-5933
MANATEE COUNTY AREA TRANSIT (MCAT)		941-749-7116
In case of emergency please call 911		
DOCK MASTER	Todd Lombardi	574-214-5651
STORAGE LOT	Tim Gregory	615-692-4885

**LOOKING FOR THE MOST
UP-TO-DATE EVENT INFORMATION?**

**CHECK THE
TRAILER ESTATES
ONLINE CALENDAR
FOR THE MOST CURRENT
EVENT DATES, TIMES &
LOCATIONS**



Everything You Need to Know About Scheduling an Event at Trailer Estates...

As of May 1st, the scheduling of ALL events is being handled by Kristin in the TE Office. She organizes and edits the Tribune, works full-time and is available year-round, making it super easy for Residents to have just "one stop" for everything event related.

If you need help with scheduling requests or have questions, you can reach her at 941-756-7177 x102 or via email at events@trailerestates.com. The Function Reservation Form (formerly PP37) can be picked up at the Office or found on the TE website under the Forms section. The form has been changed a bit, so please make sure to read it over and provide as much details as possible to ensure your reservation gets added to the calendar properly.

NOTE: Going forward, please do not send event requests and questions to secretary@trailerestates.com.

**The man who invented knock-knock jokes
should get a no bell prize.**



POOL CLOSINGS for ROUTINE MAINTENANCE

**On the 1st Tuesday of each
month, the pool is closed
all day. On the remaining
Tuesdays, the pool is
closed until 12PM.**

Recycle Information

We are having the wrong items being placed in the recycling containers. Only the following items are accepted: paper products, cardboard, aluminum & tin cans, glass, and plastic with the ♻️ symbol; however, we DO NOT accept plastic grocery store bags. Please put all other items in the solid waste dumpster. Never place items above the rim of the dumpster nor on the ground around the dumpster. Violators may be charged the cost to have the maintenance department correct the program.

MORE RECYCLE NEWS:

Motor oils can be recycled at Auto Zone, and other retail automotive stores. Batteries can be recycled at Batteries Plus. Propane tanks can be recycled at Detweilers, there is no charge. **DO NOT PUT THESE ITEMS IN DUMPSTERS!**

YARD WASTE INFORMATION:

Only brush, trees and grass (no sod) may be put in the yard waste dumpster. All other material goes in solid waste dumpster.

SOLID WASTE INFORMATION:

Solid waste dumpster is for general trash and debris. **NO FLAMMABLES, OILS, BATTERIES, CHEMICALS OR PROPANE TANKS ALLOWED.** These items can be recycled quarterly at Manatee County recycle locations at no charge. Watch your water bill for times and locations. **TV, AIRCONDITIONERS, LARGE APPLIANCES,** please call Waste Pro at 941-355-9600 for pick up.

PLEASE BREAK DOWN YOUR BOXES, UNBROKEN BOXES TAKE UP SPACE AND COST THE PARK MONEY.

Trailer Estates Tribune Submission Deadline

The **first of the month** is the deadline for items to be printed in the next month's issue. Please have all articles, notices, and/or images to the TE office by the **first of each month, no later than 3PM.** Please submit your item(s) via email to officeassistant@trailerestates.com. You can submit your items directly in the body of the email or attach as a word processing document, such as MS Word. If you do not have access to email, please contact the TE office for assistance at (941) 756-7177 x102.

TE Trash Pick-Up Schedule

OCTOBER through MAY

There will be **1** pickup on **Thursdays**

JUNE through SEPTEMBER

There will be **2** pickups

Monday and Thursday

WASTE PRO OBSERVES THE FOLLOWING HOLIDAYS:

New Year's Day

Presidents Day

4th of July

Thanksgiving Day

Martin Luther King Day

Memorial Day

Labor Day

Christmas Day

NOTE: If one of the holidays listed above falls on a weekday (Monday-Friday), trash will be picked up the next weekday.

Manatee County Animal Ordinance Reminder

Residents, renters, and/or guests of Trailer Estates with a dog please review the following:

According to ordinance 22-16, no dog shall be "at large," upon any public property, street, or sidewalk, or on private property of another, without the consent of the property owner. Additionally, the owner or custodian of a dog must have "direct control" of such animal at all times.

The following definitions are related to this section of the ordinance to assist with understanding specific meanings:

AT LARGE shall mean any dog on the owner's premises, not in the control of the owner or custodian; or any dog off the premises of the owner or custodian and not under the physical control of the owner or custodian.

DIRECT CONTROL shall mean immediate and continuous control of an animal at all times by means such as a fence, animal carrier or cage, leash, tether, cord, or chain of sufficient strength to restrain the animal or the animal shall be within the unobstructed sight, attended, and supervised by a competent person, by use of hand or voice control, when on the property of the owner or custodian, or property which the owner or custodian of the animal has the right to use.

WANTING TO MAKE A RESERVATION FOR AN EVENT IN TRAILER ESTATES?

Please send ALL Function Reservation Forms to the following email:



events@trailerestates.com

**New email as of
MAY 1, 2025**



DISTRICT

Receiving Mail & Parcels at Trailer Estates

Attention New Residents (and long-timers, too):

To ensure you receive mail, please use your TE Post Office Box Number (or another PO Box outside of TE). If you give your TE physical address as a mailing address, you will not receive your mail. Use your physical address for the delivery of parcels and/or large items like furniture and appliances. Additionally, please check that the address listed with the Manatee County Property Appraiser is an address other than your TE physical address. You can check the address they have on file by visiting their website: <https://www.manateepao.gov/search/>.

2025 Household Hazardous Waste & Electronic Scrap Collection Schedule

June 21, 2025	HHW Building/Lena Rd Landfill	9:00 a.m. – 3:00 p.m.
July 19, 2025	HHW Building/Lena Rd Landfill	9:00 a.m. – 3:00 p.m.
August 16, 2025	HHW Building/Lena Rd Landfill	9:00 a.m. – 3:00 p.m.
September 20, 2025	HHW Building/Lena Rd Landfill	9:00 a.m. – 3:00 p.m.
October 04, 2025	4410 66th St. W., Bradenton	9:00 a.m. – 3:00 p.m.
October 18, 2025	HHW Building/Lena Rd Landfill	9:00 a.m. – 3:00 p.m.
November 15, 2025	HHW Building/Lena Rd Landfill	9:00 a.m. – 3:00 p.m.
December 20, 2025	HHW Building/Lena Rd Landfill	9:00 a.m. – 3:00 p.m.



3 Poker Run Stops Still Needed!



Please Contact Margo Fegley at:
mfegley@trailerestates.com



**A perfectionist walks into a bar...
Apparently, the bar wasn't high enough.**

**CALLING ALL
VOLUNTEERS!**



Seasonal Recreation Trustee,
Margo Fegley, Needs Your Help
November 2025 - April 2026

If interested, contact Carol Ward at:
carolsward8@gmail.com



DISTRICT

Manatee County Offers Self-Service Sandbag Locations Throughout Hurricane Season

MANATEE COUNTY, Fla. (June 3, 2025) — As part of its ongoing efforts to help residents prepare for severe weather, Manatee County is making self-service sandbag locations available to the public throughout the entire 2025 Atlantic Hurricane Season.

Beginning immediately and continuing through November 30, 2025, residents can access sand and bags at the following locations from dawn to dusk daily:

- Blackstone Park – 2112 14th Ave. W., Palmetto
- Myakka Community Center – 10060 Wauchula Rd., Myakka City
- Palma Sola Park – 7815 40th Ave. W., Bradenton
- Parrish Park Overflow Parking – 77550 Ft. Hamer Rd., Parrish
- Rubonia Community Center – 1309 72nd St. E., Palmetto
- Rye Preserve – 905 Rye Wilderness Trail, Parrish
- Manatee County Stormwater Facility – 5511 39th St. E., Bradenton

Each location is self-service, so residents should bring their own shovels and be prepared to fill and transport the sandbags themselves. Bags and sand are provided at the locations while supplies last. A map of sandbag sites is available at mymanatee.org/storm by clicking on the "Sandbags" tab.

Residents are also reminded to stay up to date on local storm alerts and preparedness resources throughout the season by visiting mymanatee.org/storm and following Manatee County Government on social media.

For more information on Manatee County Government, visit online at www.mymanatee.org or call (941) 748-4501. You can also follow us on Facebook at www.facebook.com/manatee.county.fl and on X, @ManateeGov.



A/M Pressure Cleaning
SERVING FLORIDA SINCE 2008

Michael Trauth
Pressure Cleaning
Committed to Service

Specializing in Cleaning Rubber Roofs

Call or Text
941-730-6259



AMS INC.
Family Owned & Operated Since 1977

NOW Serving You From Largo, FL!

Call Today!
800-282-3572
727-471-0820

SERVING:
• Manatee
• Pinellas
• Pasco
• Hillsborough
• Hernando

The Very Best In: Window Replacement, Aluminum Roofovers, & Enclosures



Window Replacements
Built for Florida's Climate



"Our new energy efficient windows installed by AMS are beautiful. Everything from start to finish was great."

C. Wallace
Pinellas County

Aluminum Roofovers
Energy Star Compliant



10% Discount

"This is simply the best roof over system available. We love our new roof. Thanks you and your staff."

J. Howard
Pinellas County

Glass & Acrylic Enclosures
Turn your screen room into a livable lanai



"My husband and I now spend most of our time in our lovely lanai. No more rain or dirt. The workmanship is fabulous."

M. Lowery
Tampa

We also Specialize in Vinyl Siding • Carports • Sheds • Screen Rooms

Serving your community for over 35 years.
Great Price • Great Products • Great Workmanship
Your neighbors have used us. **How About You?**

Visit www.AMSOFFLA.com and view our informative video

FL State Certified • Licensed & Insured
General Contractor CG1515749 • Roofing Contractor CC C1329853

100% FINANCING AVAILABLE
(with approved credit)









SAVE TIME AND MONEY BY CALLING US TODAY TO GET YOUR PROJECT STARTED!

DISTRICT

MANATEE COUNTY SHELTER INFORMATION 2025

NOTE: ALL MOBILE HOME PARKS ARE LEVEL A AND THE FIRST TO BE EVACUATED.

Distance from TE	SHELTER NAME	SHELTER ADDRESS
5.7	Sugg Middle School	3801 59th Street West, Bradenton
9.0	Braden River Middle School	6215 River Club Blvd, Bradenton
6.6	Braden River High School	6545 SR 70 East, Bradenton
12.0	Buffalo Creek Middle School	7320 69th Street East, Palmetto
1.6	Daughtrey Elementary	515 63rd Ave East, Bradenton
9.5	Freedom Elementary school	9515 State Road 64 East, Bradenton
10.0	Gullett Elementary School	12125 44th Avenue East, Bradenton
9.5	Haile Middle School	950 I State Road 64 East, Bradenton
20.2	Harvey Middle School	8610 115th Ave, East, Parrish
4.9	Johnson K-8	2121 26th Avenue East, Bradenton
3.8	Kinnan Elementary School	3415 Tallevast Road, Sarasota
2.2	Lee Middle School	4000 53rd Avenue West, Bradenton
5.1	Manatee High School	902 33rd Street Court West, Bradenton
11.0	McNeal Elementary School	6325 Lorraine Road, Lakewood Ranch
6.6	Miller Elementary School	601 43rd Street West, Bradenton
12.0	Mills Elementary School	7200 69th Street East, Palmetto
14.0	Mona Jain Middle School	12205 44 th Ave East, Bradenton
3.4	Oneco Elementary School	5214 22nd Street Court East, Bradenton
3.8	Prine Elementary School	3801 Southern Parkway, Bradenton
4.7	Rodgers Garden Elementary	515 13th Ave West, Bradenton
6.5	Seabreeze Elementary School	3601 71st Street West, Bradenton
10.0	Tillman Elementary School	1415 29th Street East, Palmetto
13.0	Williams Elementary School	3404 Fort Hamer Road, Parrish
12.0	Willis Elementary School	14705 The Masters Avenue, Bradenton
18.0	Witt Elementary School	200 Rye Road East, Bradenton

PET-FRIENDLY SHELTERS	TELEVISION	RADIO
Shelter openings vary with each emergency. Shelter openings will differ by size and intensity of a disaster. Do not go to the shelter until local officials announce that the shelter is open. Stay tuned to local media and the County website for a listing of shelters, to include the Pet-friendly shelters, which will be opened for an event.	WFLA – CH. 8 WTSP – CH. 10 WTVT – CH. 13 WFTS – CH. 28 WWSB – CH. 40 WBSV – CH. 62 Bay News 9	WFLA – 970 AM WWPR – 1490 AM WJIS – 88.1 FM WXTQ – 106.5 FM

LOOKED UNDER YOUR MOBILE HOME LATELY?

Missing or torn insulation and vapor barrier can allow moisture, mold and mildew to build up, and provide access to insects and rodents into your home!

Call today for a FREE Under Home Inspection



floridaanchorandbarrier.com

We Also Fix Soft Floors!

**ESTIMATES
ALWAYS FREE**

**OVER 10,000
VAPOR BARRIERS
INSTALLED**

**941.448.3577
800.681.3772**



State Certified General Contractor CGC#004138
State Licensed Mobile Home Contractor #IH/102549/1
Insured • Bonded • Workman's Compensation Insurance

30 YEARS EXPERIENCE



Family Owned & Operated



Senior or Military Discounts

Board Vacancy Trustee Position (1) (Seat 4)

Qualified Electors of the District may submit a letter of interest and/or a resume/CV to the District Office **no later than Friday, August 8, 2025, 3pm.**

Applicants can pick up a copy of the duties of the Trustee (PP1) and Appointments to the Board of Trustees (PP5) in the office or on our website.

The Board is looking to fill one (1) Trustee vacancy. **You are applying for seat #4 which expires March 10, 2026.**

While a seat may be vacant, no specific duties are assigned until the Board approves the new Trustee. After the appointment is made, the new board member will be assigned their specific duties by the Chairman.

Applicant Interviews will be conducted during the Regular Workshop Meeting on Tuesday, August 19, 2025. Appointment nominations will be voted on at the Board Meeting following the Workshop. Meetings begin at 9:30 a.m.

From the Desk of the Health & Welfare Trustee

Happy July to everyone. The summer is flying by. The April blood drive went well, nine units of blood were collected which means 27 patients may be helped. The next blood drive will be in January 2026.

Tai Chi Class had 20 participants sign up and the class is going well.

I am looking for other summer activities. If anyone has a suggestion, please let me know. Meanwhile, please enjoy the amenities of our community: Pool exercise M,W,F at 9 AM, Bingo on Sunday and Wednesday opening at 6 PM in the large hall. Other activities are posted on our website. Enjoy your summer and stay safe.

~Lenora Neal
lnear@trailerestates.com

Board Meetings for 2025

The Board of Trustees of TRAILER ESTATES PARK AND RECREATION DISTRICT have set the meeting dates for January 2025 – December 2025, Mark’s Hall, 1903 69th Ave West, Bradenton, FL 34207.

2025 Board Meeting & Workshops

July 15, 2025	Board Workshop 9:30am, Board Meeting Follows
Aug. 19, 2025	Board Workshop 9:30am, Board Meeting Follows
Sept. 16, 2025	Board Workshop 9:30am, Board Meeting Follows
Oct. 21, 2025	Board Workshop 9:30am, Board Meeting Follows
Nov. 18, 2025	Board Workshop 9:30am, Board Meeting Follows
Dec. 16, 2025	Board Workshop 9:30am, Board Meeting Follows

2025 Treasure Barn Committee Meeting Dates

July – September	No Meeting	
October 2, 2025	Regular Meeting	11:30am
November 6, 2025	Regular Meeting	11:30am
December 4, 2025	Regular Meeting	11:30am

Continuing Recreation July Continuing Recreation Events

Welcome to July, folks. As the summer heat is becoming more intense, we hope the events planned for July will be a welcome break for everyone.

On Friday, July 11th, we are excited to host, “Art in the Afternoon.” This is a partnership with the Trailer Estates Ocean Air group. If you have participated in a craft project with these talented artists, then you don’t want to miss this one. All residents who participate will be painting wide brimmed summer hats- to take home! All supplies and hats are included in the \$10.00 fee. The class will be held in Mark’s Hall beginning at 2PM. The class is limited to 30 residents and when the tickets are gone...that’s it. Tickets will be sold in the office beginning Monday, June 30th through Thursday, July 3rd. Mark this fun event on your calendar. Feel free to bring your favorite refreshments. Light snacks will be provided.

To celebrate “National Ice Cream Day,” we will be having an ice cream social on Sunday, July 20th at 4PM in the large hall. This is a free event for our residents. We will be offering “do-it-yourself” ice cream sundaes with a variety of toppings, plus cookies. Save your appetite and have dessert with your friends. And since bingo begins at 7:00, you may wish to stay, play and possibly win some money.

We have moved the July movie to August, so stay tuned for the August events.

July offers some new events and lots of fun so please join us.
Until next time...KTG

PROFESSIONAL
PLUMBING DESIGN, INC.

A COMPANY YOU CAN TRUST

- ✓ Fully licensed, bonded & insured
- ✓ 100% Satisfaction Guaranteed
- ✓ Family owned and operated since 1985
- ✓ Better Business Bureau A+ rated
- ✓ Non-Commission Employees
- ✓ Non-Franchise Company
- ✓ Third party verification by:

Call The Professionals!
(941) 755-0900
www.ProPlumbingDesign.com
Lic. # CFC 057045

\$10.00 OFF Service

Cannot be used on minimum service charge and cannot be combined with any other discounts

DISTRICT

From the Desk of the Public Relations Trustees

WELCOME NEW TRUSTEE

Welcome new Trustee, Richard Fernandez, as the North Public Relations Trustee. If you see him riding around, introduce yourself and welcome him to the board.

HOUSE NUMBERS

There are a lot of trailers in the park that do not have the house number displayed on their trailer. There is a Manatee County Ordinance that states that residential dwellings are to have house numbers that are at least 4 inches high and can be read easily from the street. Manatee County Code Enforcement is supposed to be checking on this. The numbering is important in case there is some kind of emergency that your property needs to be identified. This also helps the PR trustees in identifying properties that may have an issue that needs to be addressed.

YARD MAINTENANCE

I am sure your yard maintenance people have been working like crazy since the rain the first week of June. You need to be checking on your properties to make sure your weeds and grass have been taken care of before you receive a violation. If you are not here, hopefully you have someone that can let you know if your grass and weeds need to be trimmed.

HURRICANE PREPAREDNESS

Hurricane season started June 1 and goes until November 30. If you are not going to be in the park during this time frame, it is important that you take the steps necessary to secure your home and any items outside your house. Policy and Procedure (P20A) will

give you some information to help you out. Hopefully, we won't go thru what we did last fall. PP20A also has information for residents that are here during hurricane season.

MOLD AND MILDEW

Mold and mildew are starting to be noticed on a lot of trailers and awnings. These need to be power washed and/or painted to avoid a violation.

BUILDING REPAIRS

Just a reminder that even though we have extended the moratorium on writing violations on repair issues with trailers, you still need to get an ARC permit and necessary County permits for anything that is being done on the exterior of your property. These permits need to be placed on your trailer where they are visible from the street.

SUMMER GUESTS

If you have guests visiting you or using your trailer during the summer, please register them in the office so they can get a guest FOB that will give them access to our facilities. You need to fill out the Guest Form in the Forms section of Trailerestates.com website and get it to the office. It is against our rules for the guest to use the FOB assigned to you. If your guest brings an RV, boat or any other kind of trailer, they cannot be parked at your trailer unless they are completely under your carport. Additionally, guests cannot reside in an RV on your property. An RV, boat or trailer can be parked at the Park Lane parking area if they get a parking permit from the office. See the OVERNIGHT PARKING SECTION in the Rules and Regulations.

*Rod Smith, South PR Trustee, rsmith@trailerestates.com
Richard Fernandez, North PR Trustee, rfernandez@trailerestates.com*

**WE ANSWER THE PHONE • WE SHOW UP • WE CARE
OLD FASHION CUSTOMER SERVICE YOU DESERVE!!!!**

ALUMINUM CRAFTSMEN WINDOWS AND DOORS



**Did Hurricane Milton
take a Bite out
of your Home?
WE ARE HERE TO
GET YOU BACK IN SHAPE!**

Specializing in:

**CARPORTS • LANAIS • SCREEN ROOMS
SIDING • WINDOWS AND DOORS
ALL ROOF TYPES - SHINGLE TO METAL**

*We have the Materials, Manpower
and Experience to get the Job done!*

*We provide fast turnaround
on all Mobile Home Repairs!*

**Don't wait months for your repair,
CALL US TODAY!**



*We are a Florida Licensed and Insured Local
Company with over 20 years of Experience
Rebuilding Mobile Homes!*

Call today for a FREE no obligation estimate

1-833-227-6548

aluminiumcraftsmenwindowsanddoors.com

Florida License # CGC1515394

DISTRICT



Trailer Estates Covenant Church

Bradenton, Florida
techurch1@gmail.com
941-756-7722

Lead Pastor: Rev. Dr. Rick Millikin
Pastor Emeritus: Rev. Dr. Robert Dvorak
Administrator: Eileen Koehler

Worship: Sundays at 9AM

Location: Large Hall or Mark's Hall

Broadcast: TE Channel 732 or on YouTube at Trailer Estates Covenant Church

Men's Ministry: "Fishers of Men" Wednesdays at 12PM
Lunch & Fellowship at Anna Maria Oyster Bar, Landside

Women's Ministry: Prayer at the Beach Wednesdays at 8AM (all year)
Location: TE Beach Pavilion

Monthly Meetings: 4th Monday of the Month (Jan. - Apr.)
Location: Mark's Hall

Missions: Numerous Projects (local & global) throughout the year

Trailer Estates Covenant Church has been an integral part of Trailer Estates Park & Recreation District since the Park's inception! The Covenant Church began worshipping together on December 13, 1959 and has worshipped every Sunday since, for over 60 years. We invite you to join us, all are welcome.



HOME PREPARATIONS BEFORE A STORM

IF YOU CAN PICK IT UP, PUT IT UP

Be sure to clean up any items in your yard that may become projectiles due to high winds and rain. This includes patio furniture, decorations and plants.

TE REAL ESTATE MARKET UPDATE: Sales Gain Steam

After a quiet start to the 2024/2025 season, Trailer Estates sales have gained real momentum.

While only 2 properties sold in January, 3 in February, and 5 in March—April surged with 10 sales, reflecting renewed buyer confidence and a clear sign of recovery.

Although the TE community may not match last year's total of 66 sales by the close of the full selling season, we're currently tracking at about 60% of that pace, with roughly 32 closings recorded* so far. And with sales for May, June, and July still posting—and current showing activity looking strong—there's good reason to stay optimistic.

Inventory remains higher than usual, with around 60 properties still on the market. That increased competition has driven some downward price adjustments—but it also gives buyers more choices than ever. Well-maintained homes under \$135,000 offer strong value, while premium properties with garages are still commanding prices above \$300,000.

To see the full pricing breakdown—including trends, ranges, and what it all means for your real estate goals — check out the **Market Analysis** in this month's **TE Homes & Lifestyle Magazine** at **TEHOMESANDLIFE.COM**.

**Sales data sourced from the Manatee County Property Appraiser to reflect all recorded property transfers.*

By Pamela Kemper, Azure Tide Realty
TE Resident & Real Estate Broker

"Whether you're selling, buying, or leasing—we're here to help you navigate the best path forward."

⇒ **TEHOMESANDLIFE.COM**



**Azure Tide Realty—Specializing in
Trailer Estates, Bradenton, FL**
Pamela Kemper, Broker
Email: pam@pamelakemper.com
Phone: 941-290-4859
Website: PAMELAKEMPER.COM



Public Notice Warning

According to Florida Law, consumers who knowingly hire unlicensed construction contractors could face a fine of up to \$5,000. Chapter 455-228 of the Florida Statutes allows the Florida Department of Business and Professional Regulation (DBPR) to impose a civil penalty of \$500 to \$5,000 on individuals who aid and abet unlicensed contractors. They may also be liable for court costs.

For County Issued Permitting Services call (941) 748-4501 x3800 To Report Unlicensed Contractors, call Manatee County at (941) 749-3084. Or 311.

Email: code.enforcement@mymanatee.org

The Importance of Accident and Incident Reporting

The Policy and Procedure #27B- Accident and Incident Reporting policy was adopted in 2022, and copies are available next to the first aid boxes. To quote from the policy, "If an accident or incident occurs on District property, it is critical to gather information and document the event for reporting purposes. An accident or incident is defined as any event that leads to a personal injury to a resident, guest, or visitor." This policy depends on everyone to do the right thing by reporting any accident or incident, whether you are a witness or directly involved in the event. EMS is to be called for every accident or incident occurring on District property.

Now you are probably thinking, "What do I do if I witness someone who has been injured?" We ask everyone to complete the Accident and Incident Reporting form and gather as much information as possible. Even if you did not witness the accident/incident, but come upon an individual who has been involved in an accident or appears injured, the information you provide on the form is vital. Completing this document does not hold you responsible. Once the Accident and Incident Reporting form is completed, please drop it by the office, or in the night drop box, if the office is closed. This information is shared with the District's liability carrier.

What makes Trailer Estates unique as a 55+ community is its long history of caring for each other. We ask that every resident familiarize yourself with this Policy and Procedure and act on it if you become involved in or witness an accident or incident.

**The Treasure Barn
is Closed Until
Further Notice.**

Be patient, we will be back.

**We are NOT accepting
donations at this time.**

Check Ch. 732 for updates.

Estoppel Program for Trailer Estates

Estoppel Program Cost to Process: \$100 per Estoppel (Payable to Trailer Estates)

Any person who Sells/Purchases/Makes a Title Transfer of Property within Trailer Estates Park & Recreation District must submit an Estoppel Request to the main office. This is done by the Title Company or attorney who is handling the closing. Private sales or Transfer of Title (Quit Claim) must still submit the estoppel request even if not using a title company or Attorney.

In addition, a written application from each prospective purchaser must be submitted and approved BEFORE the sale or transfer.

12. In order to maintain a community of congenial residents who are agreeable to abide by the "housing for older persons" restrictions contained in the Deed Restrictions and provisions of the Charter of Trailer Estates Park and Recreation District (hereinafter collectively "Restrictions"), the transfer of lots or parcels by any owner shall be subject to the conditions hereinafter set forth as long as said Restrictions shall remain in force and effect: It shall be necessary for the Board of Trustees of the Trailer Estates Park and Recreation District, or its duly authorized officers, agents or committee, to approve in writing all sales, transfer of title, leases or subleases of a lot or parcel, or occupation of a dwelling unit on a lot or parcel, before such sale, transfer, lease, sublease or occupation shall be valid and effective. Written application for such approval shall contain such information as may be reasonably required by application forms promulgated by the board of Trustees and shall be accompanied by a transfer fee as required by resolution of the Board, provided; however, such fee shall not exceed Fifty (\$50.00) Dollars.

Trailer Estates will perform the following actions:

1. Advise any Fines or Service Fees charged to Property by Trailer Estates.
2. Advise any outstanding Violations.
3. Require appropriate Application(s) to be filled out and completed, along with Application Fee to Live/Own/Rent Property in Trailer Estates prior to closing.
4. Age Verification & ID check (copy of Driver's License or State ID, Birth Certificate, ETC).
5. We will Disclose the Annual Assessment Cost + Any Special Assessment(s) that are in place.
6. Advise that Trailer Estates is not a Pet Friendly Community (except 46 Specific Homes).

If the Estoppel process is not followed by anyone who Sells/Purchases/Makes a Title Transfer of Property within Trailer Estates Park & Recreation District, they may be subject to Fines & Suspensions under Part E of the Rules & Regulations.

Trailer Estates Legal Notices

We have moved from The Bradenton Herald to The Observer.

Architectural Review Committee

Prior to beginning any changes to the outside of your home, you are required to submit a Deed Restriction Building Permit form for ARC approval. The Trailer Estates Deed Restrictions Building Request form is retrievable online at <https://www.trailerestates.com/forms> or can be picked up at the TE office.

ARC members meet weekly on Tuesdays in-season and the 1st and 3rd Tuesdays during summer season: June through September. ARC approval is required for all outdoor work, examples include any repairs, home removal, new home installation, roofing, gutters, awnings, stairs, windows, siding, doors, additions, carports, decks, sheds, garages, fences, gravel, cement work, pavers, and A/C.

The ARC committee has 30 days to review your completed request and inform you of approval, denial or if pending which may require further information such as a **lot survey**, or scaled drawings (required for any fence installation and other work). These surveys let you and your neighbors know exactly where lot lines are located and are for your protection. Upon approval, an orange card is issued and must be displayed in a window for six months or until the project is completed whichever comes first – please return card to drop-off box by ARC office for documentation of the completed work. All permits expire 6 months from the date of issue; if work is not completed in that timeframe request an extension prior to the expiration date; If not provided to ARC, a new form will be required. If assistance is needed or questions arise, contact active ARC committee members, the info is posted outside the ARC office door. Email: arc@trailerestates.com.

A/C Specialist

Same Day Service & Repair

FAMILY OWNED & OPERATED

RESIDENTIAL • COMMERCIAL

All Major Brands

TRANE RUUD

Goodman
Air Conditioning & Heating

Honeywell

Comfortmaker

Lic. No. CAC1815573

VISA MCO

WHEN QUALITY MATTERS MOST,
WE ARE YOUR SPECIALIST



941-404-3159

www.theairspecialist.com

FREE
Estimates & Second Opinions
On New Units

MAINTENANCE PROGRAMS

EMERGENCY SERVICE

BBB
Financing WAC

MAINTENANCE SPECIAL!

\$34⁰⁰

Preventative Maintenance Check up

Check up is for evaluation only, cleaning extra, cannot be combined with any other offers. Not valid on previous sales. Must present coupon at the time of service. New customers only.

FREE SERVICE CALL

with paid repair for new clients only

(\$69 value)

Offer valid with repair. Not valid with any other offers. Must present coupon at the time of service.



Soft Floors?

Mobile Home
2nd
Generation
Specialist

- Sub-Floor Repair/Replace
- New Laminate Flooring Install

10 Yrs Exp.



Are Your Floors Unsafe?

*FL State Licensed Mobile Home
Installer # IH-1110636
FL State General Contractor
License #1531303*

**INSURED &
FAMILY
OPERATED**



**ESTIMATES &
SMILES ALWAYS FREE**



(941) 243-7561 or (800) 377-7885

Marina News

The marina is very limited on longer size slips. If you are going to buy a boat that is over 19 feet long, **please**, call the dock master to see if we have a slip available. The Dock master has had to disappoint several people by telling them we had no place for them to dock their new boat.

Boats will only be rented slips that they fit in. For instance, if you have a boat that fits in a 28 foot slip, you will not be able to rent a 30 ft slip, if your boat fits in a 22ft slip, you will not able to rent a 26ftslip. The larger slips are for longer boats. Boats are measured from the farthest thing that sticks out on the bow to the motor in full tilt. We do not measure your boat by what it says on the registration.

If you are buying a party boat, deck boat or pontoon boat, please watch the size of the beam (width) of the boat you buy. These newer, wider boats have a hard time fitting in many of the slips without touching the sides of the decking. Please buy a boat that will give you room, on each side, to adjust with the ebb and flow of the tide.

We have 20ft. slips available! Contact Dock Master Todd Lombardi at 574-214-5651.

Leasing a Boat Slip or Storage Lot? If So, This Friendly Reminder Is For You...

- Whenever you get a new boat (vessel) registration, we need a copy of it at the office.
- Whenever you get a new registration for the trailer in your storage lot, we also need a copy of that.
- Finally, whenever you renew your insurance for the items above, we need a copy of that renewal, as well.

Spectrum Services

At Trailer Estates, we understand the importance of staying connected in today's digital age, whether it's for entertainment, work, education, or simply staying in touch with loved ones. We have partnered with Spectrum to provide a large and diverse selection of channels, high-speed internet, and one digital video recorder (DVR). NOTE: If you get the Spectrum Xumo Stream Box, you will NOT have access to the TE Channels 732 or 733.

If you need assistance with your devices or service, contact Spectrum Bulk Support at 833-697-7328 or visit their website at www.spectrum.com/community-solutions/resident-support. Additionally, you can visit their closest store, located at 4545 14th St. W, Bradenton, FL 34207.

SEWELL'S PLUMBING SERVICES, INC.

794-6497

- REPIPES • WATER HEATERS • DISPOSALS
 - REMODEL • DRAIN & SEWER CLEANING
- FREE ESTIMATES

LICENSE #CFC1426904

**RECEIVE \$25.00 OFF
ANY SERVICE CALL
WITH THIS AD***

*Limit 1 coupon per household.

* Must present coupon to receive discount.

Expires 7/31/25

HURRICANE WATCH

Hurricane conditions
are *possible* in the area
within 48 hours.

VS.

HURRICANE WARNING

Hurricane conditions
are *expected* in the
area *within 36 hours.*

Have multiple ways to monitor weather alerts and follow instructions from local officials.



1

OMG, have you heard the great news? Sewell's Plumbing Services is now doing A/C!

2

Really? That's great, but I have an A/C guy...

3

Well that's good, but I bet you're overpaying, and waiting forever for service. Me? I'm gonna stay "Cool like a Sewell" all summer long!

4

I wanna be cool like a Sewell! I'm in!

SEWELL'S PLUMBING NOW DOES HVAC INSTALLATION AND REPAIRS!

941-794-6497



SEWELL'S PLUMBING SERVICES
\$50 OFF YOUR FIRST HVAC SERVICE

CAN NOT BE COMBINED WITH ANY OTHER OFFERS
 MUST PRESENT COUPON AT THE TIME OF SERVICE



Hurricane Damage??

- Soft Spots
- Hurricane Anchors
- Leveling & Piers
- Hurricane Repairs
- Skirting
- Flooding

Toll Free: 1-(800) 429-5015
 State Licensed Mobile Home Installer
 Licensed | Bonded | Insured | IH/1148437

ATLAS

MOBILE HOME SERVICES

Call Us Today For A Free Inspection!
(941) 928-8401
www.AtlasMobileHome.com

DISTRICT

First Aid Kits

ARE LOCATED IN THE FOLLOWING AREAS:

- Share Craft Kitchen
- Men's Shower Women's Shower
- Large Hall Small Hall
- Large Kitchen Small Kitchen
- Office Shuffleboard Office

Automatic Defibrillator

Stationary units are located in the back of the Large Hall and in the hallway of the Activity Building. One portable unit is available in the Office, for use at events.

TRAILER ESTATES PARK AND RECREATION DISTRICT

Office Fees PP24

COPIES:	\$.25 per page, \$.50 two-sided page	
FAXES (Sent/Received):	1st Page	Additional Pages
FL or 800 numbers	\$ 1.00	\$ 1.00
Canada	\$ 5.00	\$ 2.00
Email	\$ 1.00	\$ 1.00

July Restroom Code: 7177

Locations of Medical Assistance

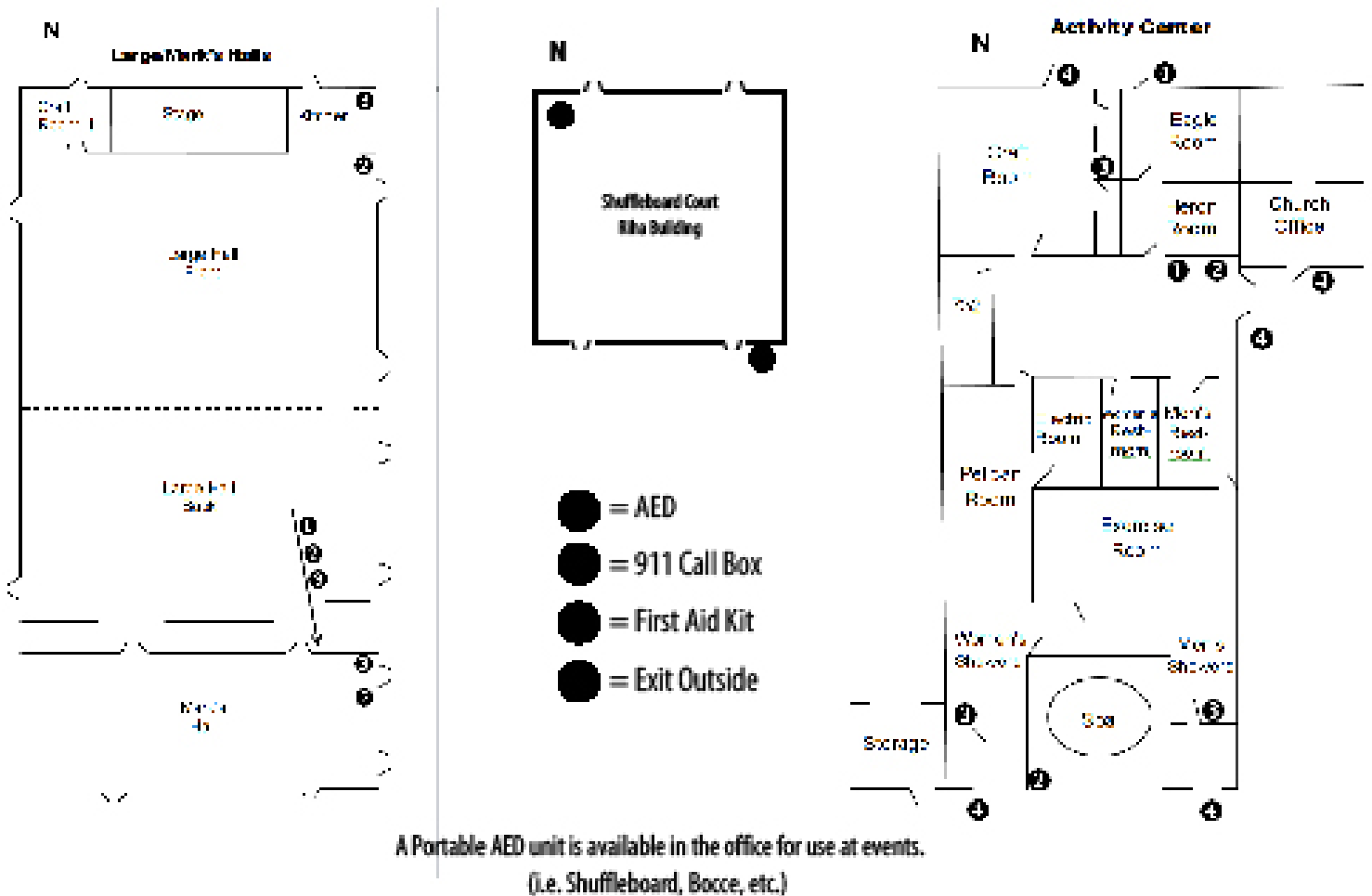

I didn't think orthopedic shoes would help. I stand corrected.

Medicare Questions? MEDICARE ANSWERS!

- Medicare Advantage Plans: PPO, HMO, Part B Give Back, Special Needs
- Medicare Supplement Insurance
- Medicare Prescription Drug Plans



Scott Black

Florida Health Resources
Independent Insurance Broker

941-302-0314

scottblackfhr@gmail.com

**LET ME SHOP THE MARKET
TO FIND YOUR CUSTOM FIT**

WE SERVICE ALL MAKES AND MODELS
AIR HEAT INC.
AIR CONDITIONING/HEATING

941-750-6313

24 HOURS

FREE SERVICE CALL w/ paid repair
\$109.00 value

ANNUAL A/C MAINTENANCE
\$74.95
NEW CUSTOMER

COMPLETE INSTALLATIONS
Starting at

2.5 TON \$4,995	3 TON \$5,175	3.5 TON \$5,361	4 TON \$5,520
---------------------------	-------------------------	---------------------------	-------------------------

DON'T FORGET!

- ★ Financing Options
- ★ VIP Programs
- ★ FREE Estimates
- ★ FREE Second Opinions

KEEPING YOU COOL ALL YEAR ROUND!

VETERAN OWNED AND FAMILY OPERATED

Licensed & Insured #CAC056961

TRANE GRANDAIR Comfortmaker



Carports



Benefits of Having a Carport:

- Easy to Maintain
- Better Protection from the Elements
- More Cost-Effective than a Garage



FREE ESTIMATES



941-448-3577



Licensed by the State of Florida CGC# 004138
Insured • Bonded • Workman's Compensation Insurance

FLORIDA ANCHOR AND BARRIER COMPANY

CLUBS & ORGANIZATIONS

Art Expressions For Beginners

Beginning Oil Painting classes will continue throughout the summer. I provide most of the materials (brushes, paints, etc.) and begin by teaching basic color mixing. A few simple projects illustrating painting techniques and then the student can choose their own subject matter and paint with my assistance. It's something to do in the long hot summer!

Class is held in the Activities Center from 9am - 12 Noon on Fridays. The cost is \$10 a session. Email me at kdeleonstuart16@gmail.com or text 941-753-4760 if interested or for more information.

~Karen Stuart

A Message from the Art Club

While the art club is now on break until next January, the art room will remain open on Mondays from 12PM-4PM, so feel free to come join us. Enjoy your summer and we will see you next year!

Bocce Club

Bocce play is ongoing every Monday, Wednesday, and Friday at about 11:15AM until about 1PM. Night play is usually Tuesday at about 6 PM. Any TE resident or renter (or guest) can play regular Bocce (only members can play in tournaments). Hope to see you there!

CERT

We are "Neighbors Helping Neighbors"

Website: www.cert-te.org



www.mymanatee.org/CERT

Phone: C.E.R.T. 752-7421 or 962-4437

Email: originaltr@cs.com

Hurricane season is here and the need for more trained CERT volunteers is critical to continue to provide our community the services they deserve in the event of another hurricane season. There is still time, we will put on a certification class as soon as we have 10 volunteers sign up for the class. They do not all need to be from Trailer Estates. We have instructors certified to provide the training and certify you as a team member. Your training is recognized everywhere in the United States as well as some foreign countries. There is never a charge for the training. The class is approximately 24 hours broken down into 4-hour increments. Use the email address or call the above numbers for an application.

In addition to surveying the damage and assisting anyone hurt, CERT has the capabilities to obtain emergency services when communications are not available to all of us. CERT will request the emergency services that you need. CERT also reports to Emergency Management the conditions which brings emergency assistance to our community.

Manatee County receives credit for CERT volunteer hours and the annual adjustment for that credit is now \$33.00 per hour for each hour reported to Manatee County. Our team reports monthly to Manatee County. CERT voluntary service saves \$\$\$ for the taxpayers of Manatee County.

Our team members are required to evacuate and we do. We encourage everyone to heed the Emergency Management evacuation orders. We do not return until it is safe to do so. When we determine the safety of our own home, we assemble with our team

to assist neighbors in need. This is a part of our FEMA training and instructions.

Disaster preparedness: Instructs team members how to prepare themselves and their community for the various types of hazards that may occur.

- Team organization and disaster psychology: Learn to work well in a team setting under a stressful emergency event.
- Fire safety: Covers proper techniques for preventing and extinguishing small fires.
- Medical operations: Conduct triage, establish medical treatment areas, and provide basic first aid for victims.
- Basic search and rescue: Learn search and rescue planning, techniques, and rescuer safety.
- Terrorism Awareness: Define terrorism, terrorist goals, weapons, and indicators of a terrorist attack.

With the authorization of the Trailer Estates Post Office, CERT has presented an Automated External Defibrillator (AED) for use on heart attack victims. This will provide the necessary assistance should it be needed and will augment AEDs that already exist in the community. It was donated to CERT by Ernie Withers of the Defibrillate Manatee Foundation and is behind the window at the post office.

CERT thanks the community for their continuing support of CERT. The funds raised by CERT stay in Trailer Estates to serve our residents. Our volunteers do not receive any remuneration.

Visit our website for more information about our CERT and at

FEMA.gov.

STAY SAFE

***Specializing in Trailer Estates
Real Estate for over 47 years***

MICHELLE ROBERTS WATSON
Broker 941-920-7368

KIMBERLY MARLER
Broker - 941-376-6146

C.E. "BUTCH" ROBERTS
Broker Associate

DOTTIE ROBERTS
Broker Associate - 941-741-1741

HARRY FALCK REALTY, INC.
LIC. REAL ESTATE BROKER
6840 14TH STREET WEST
BRADENTON, FL 34207

941-756-8811

Email: HarryFalckRealty@aol.com
www.harryfalckrealty.com

WEEKLY EVENTS

KEY

A - Activity Center
B - Beach

CR1 - Craft Room
CR2 - Craft Room

H - Large Hall or Small Hall
2 WS - Woodshop

MONDAY

H 8:30 AM Horseshoe Club
CR2 9:00 AM Pickleball
A 9:00 AM Open Craft Studio
A 9:00 AM Pool Aerobics
A 10:00 AM Pin Shuffle
A 12:00 PM MahJong
A 12:00 PM Watercolor Painting
H 5:45 PM Jazzercise
A 6:30 PM Bid Euchre
A 6:30 PM Euchre

TUESDAY

Pool is Closed (All day on the first Tuesday & until Noon the remaining Tuesdays)

H 8:00 AM Jazzercise
A 12:00 PM Group Poker
A 1:00 PM Rummikub
CR2 6:00 PM PM Pottery Class
A 6:30 PM Pinochle
A 6:30 PM Bid Euchre

WEDNESDAY

B 8:00 AM Women's Ministry
 8:30 AM Horseshoe Club
H 9:00 AM Pickleball - check website calendar
A 9:00 AM Pool Aerobics
A 10:00 AM Pin Shuffle
CR2 4:00 PM Pottery
A 5:00 PM CEBU West Club
H 6:45 PM Bingo

THURSDAY

H 8:00 AM Jazzercise
CR2 9:00 AM-5:00 PM Open Craft Studio
CR1 12:00 PM Watercolor Painting
A 1:00 PM Rummikub
A 5:00 PM CEBU West Club
CR1 5:30 PM Hand & Foot
H 5:45 PM Jazzercise

FRIDAY

H 8:30 AM Horseshoe Club
H 9:00 AM Pickleball
A 9:00 AM Beginners Art Exp. Painting
A 9:00 AM Pool Aerobics
A 10:00 AM Pin Shuffle
A 12:00 PM Poker Group
CR1 12:00 PM Art Expressions Painting
A 12:00 PM MahJong
CR1 5:30 PM Hand & Foot
A 6:30 PM Euchre

SATURDAY

H 8:00 AM Jazzercise
H 9:00 AM Pickleball

SUNDAY

H 9:00 AM Church Service
H 12:00 PM Pickleball
H 6:45 PM Bingo

Locations, Days/Dates & Times are Subject to Change. Check the TE Website Calendar & Ch. 732 for Updates.

**KEEP COOL
THIS SUMMER.....**

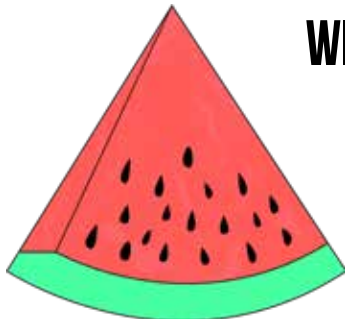

**WITH COOL
HEALTHY
TREATS!**

**If attacked by a mob of clowns,
go for the juggler.**

TARGET YOUR MARKET!

Call us today to get your ad
in one of our community newsletters!

941-723-5003



P.O. Box 161
Ellenton, FL 34222 A subsidiary of PCI Communications

www.ontracnewsletters.com

email: valerie@ontracnewsletters.com

EXPERIENCED • PROFESSIONAL • COURTEOUS

SUNDAY	MONDAY	TUESDAY	WEDNESDAY	THURSDAY	FRIDAY	SATURDAY
<p>Locations, Days/ Dates & Times are Subject to Change. Check the TE Website Calendar & Ch. 732 for Updates.</p>	<p>JULY 2025</p>	<p>1</p>	<p>2 10:00 am Tai Chi - H Pre-Registration Required</p>	<p>3 5:00 pm Cooks' Night Out - H</p>	<p>4</p>	<p>5</p>
<p>6</p>	<p>7 10:00 am Tai Chi - H Pre-Registration Required</p>	<p>8</p>	<p>9 10:00 am Tai Chi - H Pre-Registration Required</p>	<p>10</p>	<p>11 2:00 pm Art in the Afternoon - H</p>	<p>12 12:00 pm Man. Cty. Council of the Blind - H</p>
<p>13</p>	<p>14 10:00 am Tai Chi - H Pre-Registration Required</p>	<p>15 9:30 am Board Meeting - H</p>	<p>16 10:00 am Tai Chi - H Pre-Registration Required 10:00 am CERT - H</p>	<p>17</p>	<p>18</p>	<p>19</p>
<p>20 4:00 pm Ice Cream Social - H</p>	<p>21 10:00 am Tai Chi - H Pre-Registration Required 5:00 pm TEOA Paint & Sip - A</p>	<p>22</p>	<p>23 10:00 am Tai Chi - H Pre-Registration Required</p>	<p>24</p>	<p>25</p>	<p>26</p>
<p>27</p>	<p>28 10:00 am Tai Chi - H Pre-Registration Required</p>	<p>29</p>	<p>30 10:00 am Tai Chi - H Pre-Registration Required</p>	<p>31 1:00 pm Manatee Cnty. Sewer Project Q&A - H</p>	<p>KEY CR1 - Craft Room 1 CR2 - Craft Room 2 WS - Woodshop B - Beach H - Large Hall or Small Hall A - Activity Center</p>	<p>AUGUST S M T W T F S 1 2 3 4 5 6 7 8 9 10 11 12 13 14 15 16 17 18 19 20 21 22 23 24 25 26 27 28 29 30 31</p>

AllWeatherRoofing
 Your #1 Mobile Home Roofing Company Since 1984



- A+ Better Business Bureau Rating
- People's Choice Award Winner
- Celebrating 40 years in business

We Offer Financing!
FREE Estimates

1-800-297-3758
www.yourbestroof.com
 CCC-058045 CCC-1330500



Painting and Power Washing by Ralph



Interior • Exterior • Free Estimates

Ralph Suca *Your Trailer Estates Neighbor*

941-713-5308 REFERENCES AVAILABLE

DISASTER PREP TIP FOR SENIORS

Additions to your Disaster Supply Kit:

- Prescribed eye glasses
- Dentures
- All medications & prescriptions
- List of medications with dosage
- Blanket
- Medical Equipment for your conditions
 - extra batteries for equipment
- Medical bracelet or ID
- Insurance/Prescription cards
 - Medicaid/Medicare cards
- Contact list of doctors & relatives
- Walking stick/Wheelchair
- Incontinence products
 - adult diapers/liners



FLORIDADISASTER.COM/PLANPREPARE

CLUBS & ORGANIZATIONS



Cooks' Night Out Celebrates 30 Years as a Trailer Estates Club



We invite you to join us July 3rd for another great meal with friends and neighbors. CNO offers dinners from May 1st through October 2nd. The next two menu and ticket sale dates are included below, so mark your calendars.

CNO volunteers sell tickets, shop for ingredients, and cook the dinners which are traditionally held the 1st Thursday of the month. Funds raised are returned to Trailer Estates for projects that the Park might have on a “Wish List” and may not be included in the budget, or funds are donated to a local charity selected by the members.

At the CNO dinners, we have a wonderful time together, and it is a GREAT way to meet your neighbors, so PLEASE plan on attending this year!

Our Menus are subject to change but will be posted on 732, prior to ticket sales, for your information. See you soon!



Cooks' Night Out Meals – Tickets \$10 Each Post Office Ticket Sales are 10am – Noon

July 3rd at 5PM in the Large Hall

MENU: BBQ Ribs, Mac & Cheese, Baked Beans, Cole Slaw & Watermelon
(Ticket Sales: June 23 - 27 by the PO and at Bingo on June 22, 25 & 29)

August 7th at 5PM in the Large Hall

MENU: Lasagna, Salad, Vegetable, Garlic Toast & Dessert
(Ticket Sales: July 28 - Aug 1 by the PO and at Bingo on July 27, 30 & Aug 3)

CNO is for Trailer Estates residents and registered guest(s) with proper ID.

Menu is subject to change.

All proceeds are donated to Trailer Estates improvement projects.

LOOKED UNDER YOUR MOBILE HOME LATELY?

Insulation Under Your Home Falling Down? Holes and Tears in Your Vapor /Moisture Barrier?



Underhome
Photos Provided



Insulation and Vapor Barrier Repairs



- Lifetime Vapor Barrier • Guaranteed for Life • Prevent Soft Floors • Lower Your Electric Bills
- Keep Mold, Mildew, Rats, Snakes, Spiders, Ants, Roaches and Moisture OUT of Your House!



UPGRADE TO VINYL SIDING & WINDOWS!

- Low-maintenance
- Easy to Clean & Long-lasting
- Lightweight & Weather-resistant
- Resistant to Scratches & Dents
- Resistant to Insects
- Resistant to Mildew and Fungus.



If your siding is loose, cracked, or warped it may be time to replace it. Call us now for a FREE QUOTE!

Are Your Tie Downs Tight?

- Hurricane Anchors • Tie Downs
- Leveling • Blocking • Carport Tie Downs
- Stabilizing Devices • Roof-Over Strapping

- Replace Rusted Anchors • Add Anchors
- Longitudinal Stabilizing • Retro-fit to Current State Standards

If your home moves even a few inches during a storm your home will suffer severe damage. Loose tie downs do not protect your home, they must be tightened every 3 to 5 years. Have your tie-downs inspected NOW, before the storms!



Licensed by the
State of Florida
#1H/102549/1

- FREE INSPECTIONS & ESTIMATES • MILITARY & SENIOR DISCOUNTS
- FAMILY OWNED & OPERATED

941.448.3577

1-800-681-3772

- State Licensed Mobile Home Installer • Insured
- Bonded • Workman's Compensation Insurance
- Member: National Association of Mold Professionals



FLORIDA ANCHOR AND BARRIER COMPANY

CLUBS & ORGANIZATIONS

Computer Club



Safe travels and have a wonderful summer, Snowbird members! The Computer Club of TE continues to provide tech support to our members during the summer months. We also accept new members year-round.

Our Club meetings are held December – April. We are a member-to-member club serving residents and owners of TE. Join and receive tech support for your Internet and WiFi ready devices, such as cell phone, computer, tablet, smart tv, printers and more.

First training presentation of the 2025-26 season will be presented by Big Fish Technologies, the subject: "Proper Care and Maintenance for Personal Devices"

Our Club contact information is found on our web page www.ccofte.com. The membership form is also available online. The website also includes instructional articles on how to access your Spectrum TV channel lineup away from TE. Contact us for any club-related questions or to request tech support.

Call 941-281-5648 or email us at computerclubte@gmail.com and we will arrange for one of our tech support volunteers

to meet with you. Meetings and trainings schedules are posted on the bulletin board near the post office as well as on Channel 732. If you want to renew your membership or join call 941-281-5648

Karen Harker, Club President

Jazzercise Anyone?

The more you move, the better you'll feel!

Our community offers many fun ways to exercise and socialize. One great example is Jazzercise which is a free class open to the Trailer Estates residents and is offered five times per week. Jazzercise is a great way to stay fit and reach your exercise goals. Note: classes may be cancelled, or the location of the class may be changed, so always check the Trailer Estates calendar on the website for the most up-to-date information.

Neighborhood Watch

Do you know that if you are aware of 'squatters', attempted break-ins, trespassers, thefts, vandalism, or any suspicious activity there is a good team of patrollers to investigate, assist and help keep you and your property safe? NW should be notified for EVERY incident; however, if you witness an actual crime, please call 911 immediately. By then contacting NW, we can not only assist the sheriff but also follow up with continued efforts in the matter. SEE SOMETHING, SAY SOMETHING. Please help us help you.

Gary Militello NW 585-794-6153

Manatee Sheriff non-emergency 941-747-3011 X2260

Thank You, Neighbors

Citrus Homes Meadowood Homes of Florida



Scan for
Virtual Tours
of All Models

www.MyJacobsenHomes.com

Schedule a Tour to Our Sales & Model Center

5327 14th St. W

Bradenton, FL 34207

(1 Block South of SR 70 on US 41)



My JACOBSEN HOMES
(941) 758-3633

WE ARE FLORIDA'S #1 RETIREMENT COMMUNITIES PARTNER!



**Mobile Home
2nd
Generation
Specialist**

Quality Workmanship Honest Pricing

- **Vapor / Moisture Barrier**
- **Underhome Encapsulated Insulation**
- **Hurricane Tie-Down Anchors** **10 Yrs Exp.**

To our valued customers:

Our top priority is the health and safety of our employees and our customers. Our employees are closely following the Centers for Disease Control (CDC) guidelines and recommendations, like frequent hand washing, social distancing, and staying home if they are feeling ill.

We have taken steps to limit exposure to the virus by making our customers aware that there is no need to have any contact with our employees if you choose to do so. Our business falls under the state's guidelines as "Essential Business".

We want to build a great relationship with you. Call today for your Free Inspection. (800) 377-7885

Stay Safe and Continued Good Health.
Underhome Armor Family

We Keep rodents, snakes, spiders, bugs, mold, mildew, and damaging moisture out of your home!



**LIC. # IH-1110636
INSURED
FAMILY OPERATED
FL State General
Contractor Lic. # 1531303**



**FAMILY
OPERATED**



**ESTIMATES &
SMILES ALWAYS FREE**

(941) 243-7561 or (800) 377-7885

CLUBS & ORGANIZATIONS

Trailer Estates Ocean Air (TEOA)



Trailer Estates Ocean Air (TEOA) – Where Creativity and Connection Thrive!

Trailer Estates Ocean Air is a resident volunteer group focused on bringing creativity, connection, and fun to our amazing community! Whether you love painting, cooking, creating, or just enjoying time with your neighbors, TEOA is all about small, informal events that bring people together in fun and meaningful ways.

Be sure to follow our Facebook group for the most up-to-date details about events and activities. To do that, log onto Facebook, search for Trailer Estates Ocean Air, and join—or go to:

www.facebook.com/groups/trailerestatesoceanair/

Event activities are also listed on TrailerEstates.com and on Channel 732.

Upcoming Events:

• TEOA Paint & Sip

3rd Monday Each Month from 5 - 7PM in the Activity Center Craft Room. Join us for painting and socializing. No painting experience is necessary as you will be guided through a project. Seating is limited to 24 people, so get a ticket to reserve your spot for each separate event date on our Trailer Estates Ocean Air Facebook group. Bring a drink to sip, an apron, and we'll supply the rest!

• TEOA Art Popup Events

Watch for announcements regarding the theme for this additional creative popup event that goes beyond the classic canvas! Projects include creating dimensional wooden signs, painting wooden ornaments, canvas bags, and more. Reservation Tickets will be required to reserve your spot found on our Trailer Estates Ocean Air Facebook group.

• Social Events

Find social event announcements made by group members such as gatherings at a fellow resident's house, get-togethers at the TE pavilion for games, following a local band at a nearby

hot spot, organizing outings to community events, or heading to the beach with neighbors. (All event posts must follow rules found under "Featured" on our Facebook page.)

Your TEOA Admins: Pamela Kemper, Janice Lombardi, and Jennifer McKee. Find us on Trailer Estates Ocean Air or email Janice at lombardijanice@msn.com or call or text Pam at 941-290-4859.

Woodshop News

If you're getting ready to head north, we wish you safe travels and a wonderful summer, and look forward to welcoming you back next season. Members, please remember, on your return, to renew your membership and sign your liability forms on or after October 1, 2025. Anyone staying, The Shop is still open and ready to sign you up, as there are some on-going classes and room for more Laser members.

Take good care and all the best, from everyone at the Wood Shop.

TE Veterans Club

We hope everyone is traveling safely and having a good summer. The Veterans Club is in the process of planning the 11/11/25 Veteran's Day Ceremony. Volunteers are needed for the Veteran's Day ceremony. If you have an interest in being involved, let the Club know.

The Veterans Club of TE is a social club comprised of those who have served in the US or Canadian military, family members of veterans, friends and anyone else supportive of veterans and who is a resident or owner in TE and interested in participating in this Club.

The Veterans Club meetings are October – April on the first Thursday at 1 PM in the Activity Building, Pelican Room. First year dues are \$10.00 with renewals at \$5.00 per year. Come to a meeting and check us out. Club email is veteransclubofte@gmail.com. Our phone number is (941) 254-1023. It is a message number.

R.I.P. boiled water. You will be mist.

DISASTER PREPAREDNESS TIP

IMPORTANT DOCUMENTS

- Ensure all personal documents are up to date, including your insurance policies and ID.
- Make a list of all important items in your home and keep it with all of your documents.
- Make copies and keep them in a waterproof container and/or a secure password-protected digital space.

FLORIDADISASTER.ORG/PLANPREPARE

COMMUNITY

Free Estimates

ROOFING OF FLORIDA, INC.



Lic# CCC1330642

"Proudly Serving Your Community" • Family Owned and Operated
100% Maintenance Free Roofs!

We Do All
Roof Overs, Roof Coatings,
Roof Repairs & Inspections
on all Manufactured Homes

800-511-2517



Lifetime Warranty on Labor & Materials!
www.CommunityRoof.com

Jazzy July Recipes

GINGER MINT PALOMA COCKTAIL

- 2 oz. tequila
- 1 oz. fresh grapefruit juice
- 3/4 oz. fresh lime juice
- 1/2 oz. ginger syrup
- 8-10 mint leaves
- 2 dashes orange bitters

Garnish: half moon grapefruit slice and mint sprig



SPICY MANGO WHIPPED GOAT CHEESE

Ingredients:

- 6 oz. cream cheese, softened
- 6 oz. plain goat cheese, softened
- 1 clove garlic, grated
- 2 Tbsp. chopped fresh basil, plus more for serving
- Kosher salt
- 2 Tbsp. extra-virgin olive oil
- 1 cup finely chopped fresh mango
- 1/2 cup mango chutney
- 1/2 tsp. cayenne pepper
- 2 Tbsp. chopped roasted, salted cashews
- Pita chips, for serving

Instructions:

In a food processor, pulse cream cheese, goat cheese, garlic, basil, and 1/4 teaspoon salt until smooth, 15 to 20 seconds. With the motor running, drizzle in oil and blend until mixture is smooth and fluffy, about 1 minute. Transfer to a serving bowl.

In a medium bowl, mix mango, chutney, and cayenne. Spoon over top of whipped cheese. Top with cashews and more basil. Serve with pita chips alongside.

CHERRY-PISTACHIO OLIVE OIL CAKE

Ingredients:

- 2 cups all-purpose flour
- 2 tsp. baking powder
- 1 tsp. kosher salt
- 1 1/4 cups granulated sugar
- 2 tsp. grated lemon zest, plus 2 Tbsp. fresh juice (from 1 lemon), divided
- 1 cup extra-virgin olive oil
- 3/4 cup whole buttermilk, at room temperature
- 3 large eggs, at room temperature
- 1 tsp. vanilla extract
- 1 cup fresh (or thawed frozen) pitted cherries (patted dry)
- 1/4 cup chopped unsalted dry-roasted pistachios
- Powdered sugar, for topping

Directions:

Preheat oven to 325°F. Grease a 9-inch round cake pan (with 2-inch-tall sides) with cooking spray; line bottom with parchment. Whisk together flour, baking powder, and salt in a medium bowl. Set aside.

Place granulated sugar and lemon zest in a large bowl, and rub zest and sugar between your fingers to release oils from zest. Whisk in olive oil, buttermilk, eggs, vanilla, and lemon juice until smooth.

Whisk in flour mixture until combined. Transfer batter to prepared pan. Sprinkle with cherries and pistachios. Bake until a wooden pick inserted in center comes out clean, 45 to 50 minutes.

Let cool in pan for 15 minutes; remove from pan, and transfer to a wire rack to cool completely, about 1 hour, 30 minutes. Dust with powdered sugar, as desired, just before serving.

GRILLED SHRIMP AND AVOCADO SALAD

Ingredients

- 1 pound large shrimp, peeled and deveined
- 3 large ears of corn, husked
- 2 tablespoons extra-virgin olive oil, divided, plus more as needed
- 1/2 teaspoon good quality chili powder
- Kosher salt and freshly ground pepper
- 2 tablespoons fresh lemon juice, plus more to taste
- 2 tablespoons fresh chopped dill
- 2 ripe avocados, pitted and sliced
- 2 cups mixed salad greens
- 4 cups baby romaine or bibb lettuce, cut, washed and dried
- High quality finishing salt

Instructions

Preheat the gas grill or grill pan to medium-high. Brush shrimp and corn with 1 tablespoon of olive oil and season with chili powder, salt and pepper. Grill shrimp about 2 minutes per side, or until opaque. Transfer to a rimmed baking sheet. Grill corn until lightly charred on all sides and transfer to a rimmed baking sheet with shrimp and cool completely.

When cooled, slice shrimp in half lengthwise by slicing along the back of the shrimp and through the indentation where the vein was removed. Use a corn stripper or a serrated knife to remove the grilled corn from the cobs. Transfer shrimp and corn to a medium bowl and toss with lemon juice and dill. Taste and adjust seasoning with salt and pepper. Carefully fold in avocado, taking care not to mash the slices. Add additional lemon juice and olive oil as needed to thoroughly coat.

To serve: Arrange the salad greens between chilled plates. Spoon shrimp mixture generously over the top of each salad. Finish each salad with a dusting of finishing salt and black pepper. Serve immediately.

The rotation of Earth really makes my day.

Hurricane Season is here!



Protect your home and your neighbor's - Please secure all loose items around your home!

PRESCRIPTION MEDICATION ACCESS PRIOR TO A DISASTER

Individuals may refill prescription medications in advance for at least a 30 day supply if they live in a county that is:

- Under a hurricane warning issued by the National Weather Service
- Declared to be under a State of Emergency in an Executive Order issued by the Governor
- Has activated its emergency operations center



HURRICANE SEASON IS HERE. *IS YOUR HOME READY?* **SECURE IT WITH CONCRETE TIE-DOWNS.**

Our tie-down system is installed directly into the concrete slab of your lanai or carport for maximum wind resistance, while traditional tie-downs can fail when the ground becomes saturated during storm season.

**INVEST IN THE PEACE
OF MIND KNOWING
YOUR HOME IS SECURE!**



avg. cost
only \$100
per column



**Caruso & Sons
Home Services**

**CALL TO
SCHEDULE
YOUR APPT. TODAY
941.413.8195**

**VETERAN OWNED +
FAMILY OPERATED**

**TRAILER ESTATES PARK AND RECREATION DISTRICT
SUNSET BEACH WALKWAY
COMMEMORATIVE BRICK ORDER FORM**

Each brick may contain three (3) lines with up to 13 characters per line (lines will be centered). Spaces and punctuation such as commas, periods and hyphens are counted as one character. A heart counts as 2 or 3 spaces. Trailer Estates reserves the right in its sole discretion to deny any application and return brick donation.

I would like my personal inscription to read: PLEASE PRINT

	1	2	3	4	5	6	7	8	9	10	11	12	13
Line 1													
Line 2													
Line 3													

Name _____

Street address _____ P.O. Box _____

City _____ State _____ Zip _____

Phone (____) _____

Method of Payment: \$100 per brick Check/Money Order _____ Cash _____

Payable to: Trailer Estates
P.O. Box 6298
Bradenton, FL 34281-6298

Walkway number A B C
(Circle one)

I verify that all the above information is correct.

_____ Date _____
Customer Signature

TRAILER ESTATES PARK & RECREATION DISTRICT - FY 2024-2025 PRICING

BOAT SLIP RENTALS BY SIZE							
RESIDENT Cost				NON-RESIDENT Cost			
SLIP		Base	w/Tax	SLIP		w/Tax	
20 FT	12 MTHS	520.94	549.59	20 FT	12 MTHS	1,701.71	1,795.30
	6 MTHS	286.51	302.27		6 MTHS	935.94	987.42
24 FT	12 MTHS	625.12	659.50	24 FT	12 MTHS	2,099.94	2,215.44
	6 MTHS	343.81	362.72		6 MTHS	1,154.96	1,218.48
26 FT	12 MTHS	677.21	714.46	26 FT	12 MTHS	2,275.90	2,401.07
	6 MTHS	372.47	392.96		6 MTHS	1,251.74	1,320.59
30 FT	12 MTHS	781.40	824.38	30 FT	12 MTHS	2,604.66	2,747.92
	6 MTHS	429.77	453.41		6 MTHS	1,432.56	1,511.35

\$25.00 / 26.63 Repositioning of boat from one slip to another each occurrence.

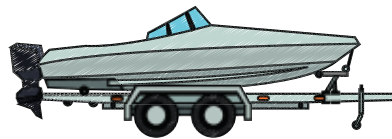

STORAGE LOT RENTALS- Residents Only

Lot Size	Term	Base	w/Tax
18 FT	12 MTHS	270.89	285.79
	6 MTHS	148.98	157.17
20 FT	12 MTHS	302.03	318.64
	6 MTHS	165.54	174.64
24 FT	12 MTHS	361.18	381.04
	6 MTHS	198.65	209.58
30 FT	12 MTHS	451.48	476.31
	6 MTHS	248.31	261.97
40 FT UnPaved	12 MTHS	601.97	635.08
	6 MTHS	331.09	349.30
40 FT Paved	12 MTHS	636.70	671.72
	6 MTHS	350.19	369.45
50 FT	12 MTHS	795.87	839.64
	6 MTHS	437.73	461.81

CANOE / KAYAK RATES



Annually	115.76	122.13
----------	--------	--------

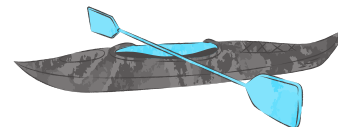

SUB-FLOOR & FLOORING EXPERTS!

Sub-Floor Repairs



Laminate Flooring



STATE CERTIFIED GENERAL CONTRACTOR
CGC# 004138
STATE LICENSED MOBILE HOME CONTRACTOR
#IH/102549/1

FLORIDA

**ANCHOR AND BARRIER
COMPANY**

**FREE
ESTIMATES**

**30
YEARS
EXPERIENCE**

**LICENSED
INSURED
BONDED**

941.448.3577 800.681.3112



UPGRADE TO VINYL SIDING & WINDOWS!

- Low-maintenance
- Easy to Clean & Long-lasting
- Lightweight & Weather-resistant
- Resistant to Scratches & Dents
- Resistant to Insects
- Resistant to Mildew and Fungus.

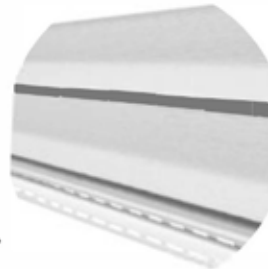

If your siding is loose, cracked, or warped it may be time to replace it. Call us now for a FREE QUOTE!



**ARE YOUR
TIE-DOWNS
TIGHT?**

**ARE YOU
SURE?**

WE CAN FIX YOUR SOFT FLOORS!

WE ALSO SPECIALIZE IN MOBILE HOME FLOORING REPAIRS, AND LAMINATE FLOORING.

FLORIDA
**ANCHOR AND BARRIER
COMPANY**



STATE CERTIFIED GENERAL
CONTRACTOR
004138

STATE CERTIFIED
MOBILE HOME INSTALLER
#IH/102549/1

ESTIMATES ALWAYS FREE FAMILY OWNED & OPERATED

941.448.3577 800.681.3772

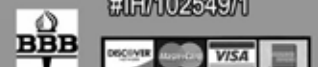

“My care team is thinking about the long term. I like that.”

Peter Crampton | Sarasota, FL



These days, turning 60 doesn't mean you're ready to slow down. You just need a little more help than you used to. The first step? A primary care provider who takes the time to understand who you are—and what you want to do next.

Peter's next big thing is improving his short game, and we're going to make sure he's ready. What's next for you?

Healthcare for what's next.



Scan the QR code to learn more or call (941) 297-2126.



ArchWell HEALTH

Primary Care for Floridians Age 60+

Visit ArchWellHealth.com/OrangeCouch to hear how members are living their best lives better with ArchWell Health!

Financing Available

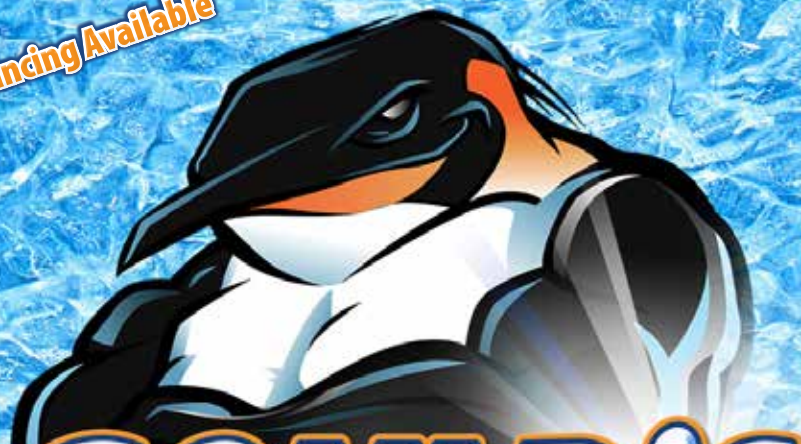

GOULD'S AIR CONDITIONING & HEATING

941-993-9700

www.GouldsAC.com

SYSTEM INSTALLATION AND REPAIR

Trusted • Fair Prices
Fast & Responsive
Satisfaction Guaranteed



Your neighborhood experts in comfort and care!

Sam Cell:
813-763-6291



License: CAC1816446



VICKI OLER SENECA

Listing Specialist

RSPS, AHWD, GRI

941-228-0610

vickioler@aol.com



SARASOTA
GLOBAL REALTY



FULL SERVICE REPRESENTATION MULTIPLE LISTING SERVICE

I am a Trailer Estates resident.







BOB'S AIR

Lic # CMCI251566

941-929-3541

www.BobsAir.com

-  **Mobile Home AC Specialists**
-  **We Do Ductwork!**
-  **Senior & Military Discounts**
-  **Licensed, Bonded, Insured**



• FREE DUCT INSPECTIONS •